

NEWTEC WEIGHING MACHINE

A-SERIES

h2009A / h2014A



GENTLY ROTATING
BRUSHES FOR SOFT
HANDLING OF APPLES

NO DROPS

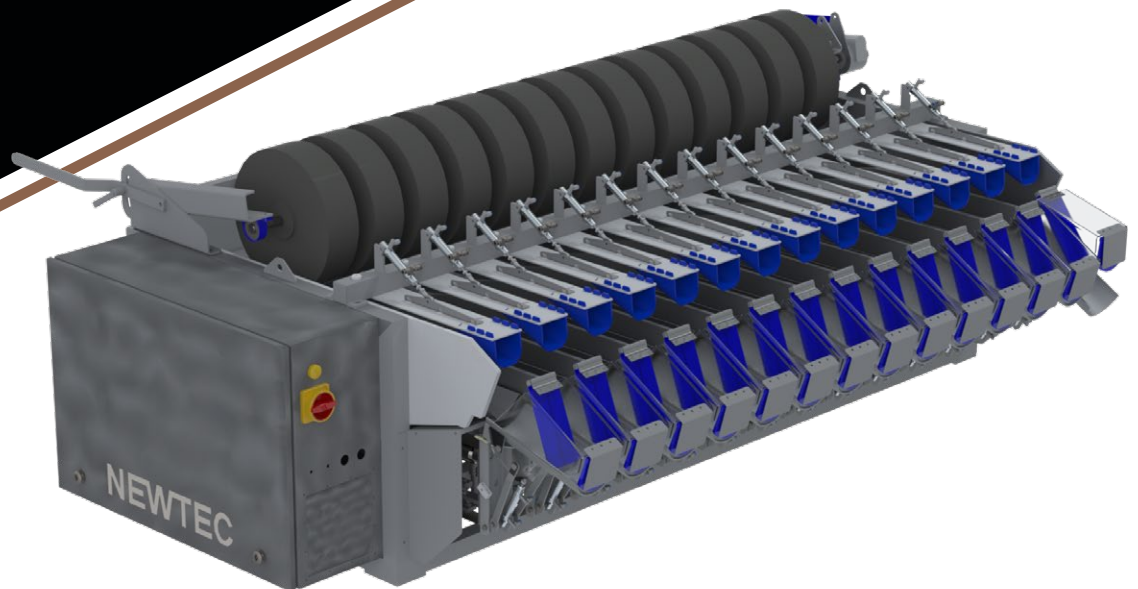

Specially designed for gentle handling of apples

Advantages

- Robustly constructed in stainless steel
- Apples are gently rolled through the weighing process – no drops
- Combining high speed and high weighing accuracy
- Option: Extended weigh heads for large portions
- Option: Newtec WebServices for remote servicing, data collection and analysis
- Option: MachineLink for easy control of more Newtec machines in mix line solutions

Application

Round, fragile products such as:

- Apples • Tomatoes • Similar round and fragile products



WEBSERVICES AVAILABLE
FOR REMOTE SERVICING

YOUR ADVANTAGES

- User-friendly software – programmable in seconds
- Count by weight, minimum weight, or average weight programs
- Capable of running with one or more channels disabled.
- Easy access for cleaning and service
- OPTION: Photocells for counting
- OPTION: A or AL weigh heads

- Slide (h2014A)
- Cradle (h2014A)
- Cross Conveyor (h2009A)

OPTIONAL PORTION COLLECTION SYSTEMS

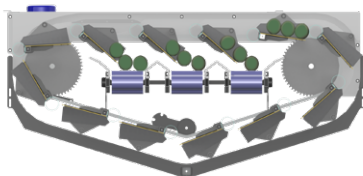

Slide

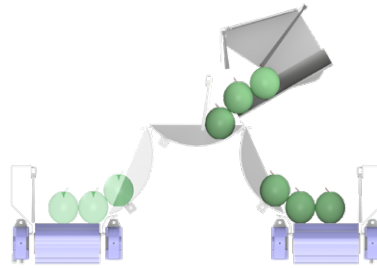

Cradle

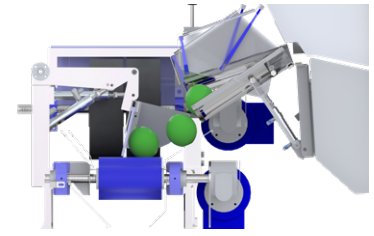

Cross Conveyor

Round brushes gently prevent bridging of products

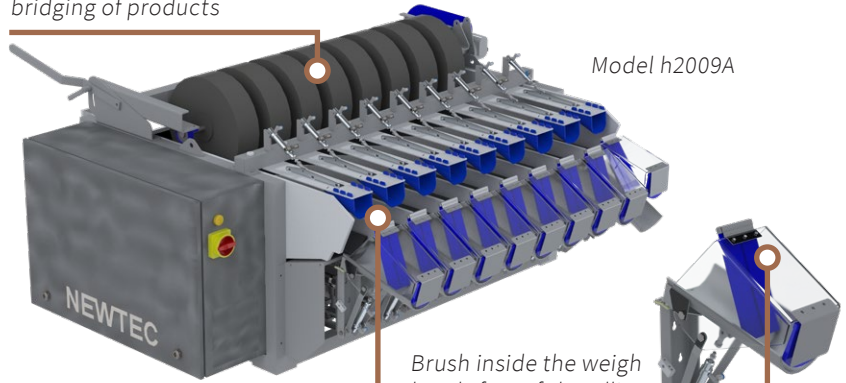

Model h2009A

Brush inside the weigh heads for soft handling

- Height: A 204 mm / AL 232 mm
- Width: 108 mm
- Depth: A 250 mm / AL 330 mm
- Theoretical vol: A 3,3 L / AL 3,7 L

Stop flaps

- Hygienic material
- Easy to clean

COMBINATION WEIGHING MACHINE WITH 9 / 14 CHANNELS

Model	h2009A	h2014A
Speed / Capacity	Portions per min. up to (depending on PCS)	
Apples	1 kg. 26 1,5 kg. 24 2 kg. 24	50 40 40
Weight	350 kg.	453 kg.
Portions sizes	1-2 kg.	1-2 kg.
Air requirement		
Connection	3/8"	
Min. pressure	7 bar (0.7 Mpa) (100 psi)	
Consumption	150 NL/min.	
Weigh head volume	2,9 L / AL 3,7 L	
Max product size	Ø 100 mm	
Material	According to the EU/FDA rules on food contact materials	
Protection class	IP54	
Electrical requirement	3x220 VAC or 3x400 VAC (N)+PE	
Environment	5° C – 35° C	

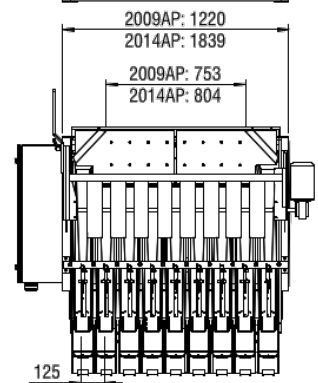
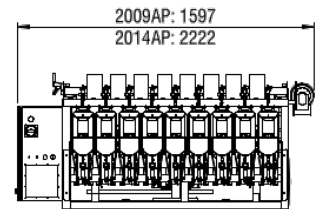
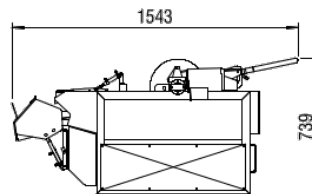

NEWTEC SOFTWARE

- Intuitive user interface
- Informative and upgradable
- Same user interface on all Newtec weighing and packing machines

